

WP 110

WEATHERPROOF PAGING SYSTEM WITHOUT INDICATION



Mechanical Data

Material	: FRP
Weight	: 5.0 Kg (Approx.)
IP Protection	: IP 65 as per IS 13947/1993/IEC 6+0529/ 1989
Cable Entry	: 2 x 1/2" ET (Max.)
Gasket	: Neoprene
Hardware	: Stainless Steel
Terminals	: 4 x 2.5 sq.mm (Standard)
	: 6 x 2.5 sq.mm (looping)

Electrical Data

Voltage	: 24 V DC or 110 V / 230 V AC - 50 Hz
Maximum Power consumption with filament lamp	: 1500 mA at 24 V - 36 Watts, : 300 mA at 230 V - 69 Watts,
Sound Output	: 112 dB for 24/110 / 230 V

Description

Weather Proof Telephone activated paging station with Audio alarm facility. Main chamber housing safe output electronic circuit, duly encapsulated. A hooter cum voice annunciation unit is incorporated. The unit is duly wired up to the terminals. The covers are provided with neoprene 'O' ring for weather proof protection. (IP-65)

GA Drawing

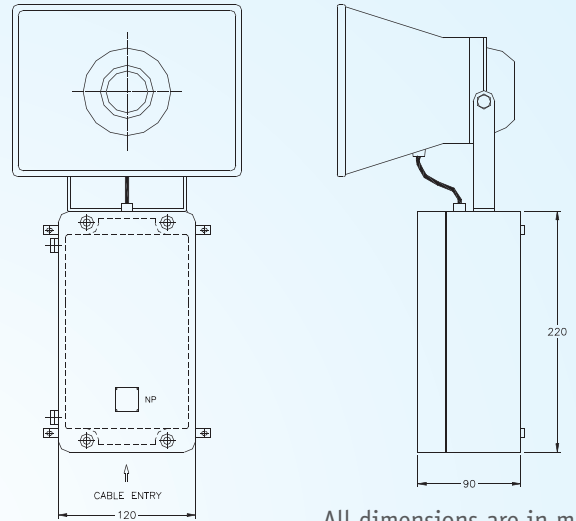

All dimensions are in mm

Type of protection	Weatherproof
Area Classification	IP 65
Apparatus Standard	IS - 13947 / 1993 / IEC 60529 / 1989
Wattage Rating	25 W

Salient Features

This unit incorporates a Telephone activated paging with the following facilities.

- A** Selectable Ringer Sequence
- B** Voice Annunciation through speaker with adjustable volume control.
- C** Telephone voice in speaker will come on after the Ringer sequence

1

2

3

4

IF IN DOUBT ASK

DO NOT SCALE

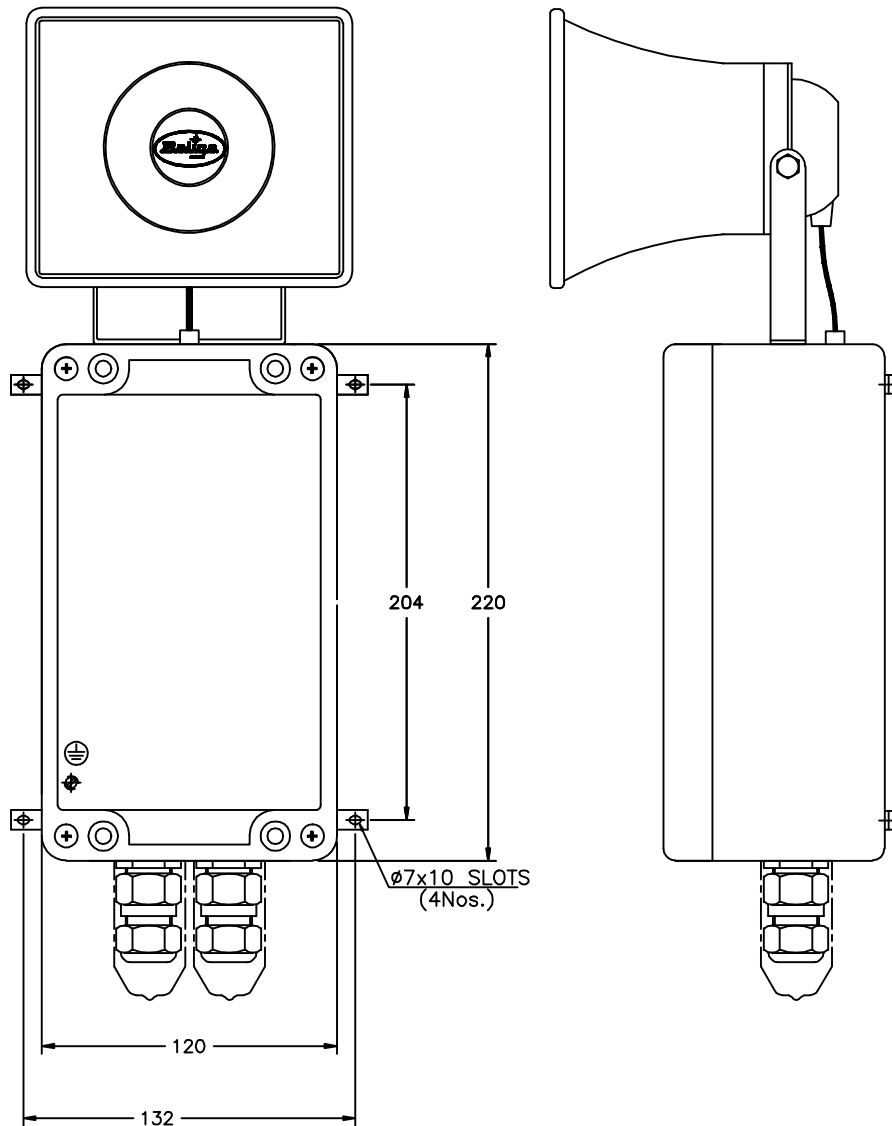

ALL DIMENSIONS ARE IN MM.

E	<u>CABLE ENTRY</u> 2Nos. M16X1.5P <u>WP CABLE GLAND:</u> 2Nos. M16X1.5P BRASS NI.PLATED DOUBLE COMPRESSION TYPE GLAND WITH CHECKNUT WITH PVC SHROUD MAX CABLE OD : 16mm	CUSTOMER :	TITLE : WEATHERPROOF PAGING SYSTEM			
		CONSULTANT : -	CAT No. : WP-110			
F		PROJECT : -	CLASSIFICATION : IP65			
		P.O No.: -	WT:- (APPROX.)	MATL :- FRP	ITEM No:	QTY:
		FINISH : GREY	TOLERANCE : ±5mm		FOR INFORMATION ONLY	
		IS:12063/87 (IEC:60529/89)	SCALE N.T.S			
			REV-1	NAME	DATE	SHEET 1 OF 1
	REV-2					
	DRN. S.S	19.05.09	DRG. No.	REV		
		CHKD. SS	19.05.09	QWEP110001	0	
		APPD.				



Baliga Lighting Equipments Private Limited,
 KOVILAMBAKKAM, CHENNAI-600 117, INDIA.

1

2

3

4